

NOT FOR  
CONSTRUCTION

# 100 LECKY ROAD PTY LTD BANYAN PLACE ESTATE FLP STAGE 5 70-100 LECKY ROAD, OFFICER CARDINIA SHIRE COUNCIL

## SHEET INDEX

1. LOCALITY PLAN, TYPICAL CROSS SECTIONS, SOT & SHEET INDEX
2. DETAIL PLAN
- 3-4. TURNING TEMPLATES

### FUNCTIONAL LAYOUT PLAN APPROVAL

CARDINIA SHIRE COUNCIL

Ref No.: S21-169  
 Sheet: 2 of 5  
 Approved by: Justin Conn  
 CARDINIA SHIRE COUNCIL  
 Date: Tuesday, 28 February 2023

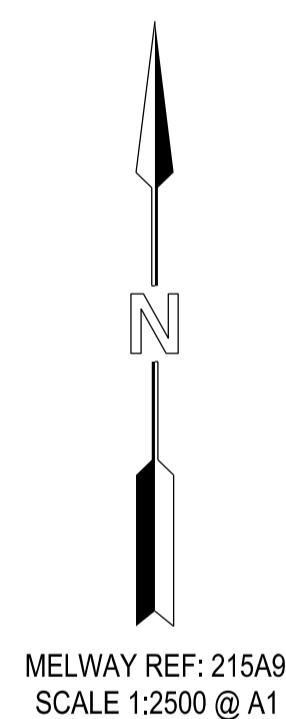

### VERSION DETAILS:

REV	DATE	DESCRIPTION	STATUS
A	04/06/2021	PRELIMINARY ISSUE	PRELIMINARY
B	21/06/2021	ADDITIONAL LOT ADDED. LOTS 520, 521, 522, 537 & 538 AMENDED.	PRELIMINARY
C	25/11/2021	KERB & ROAD X-SECT AMENDED, TURNING TEMPLATES ADDED. LOT 521 CROSSOVER SWAPPED.	PRELIMINARY
D	09/02/2023	CAR PARKING SPACES ADDED, DRAINAGE AMENDED & SPEED HUMP ADDED TO WATERRIBBON RD	PRELIMINARY

FILENAME: P:\1470\1470\_5IE2 - Design\6 - DGN\FLP01\_S15.dgn

DRAWN:	RC	DATE:	JUNE 2021	SCALE:	AS SHOWN
DESIGNED:	RC	DATE:	JUNE 2021	DATE PRINTED:	9/02/2023
AUTHORISED:	RB	DATE:	JUNE 2021		



SUITE 1, LEVEL 1, 84 MT ELIZA WAY, MT ELIZA VIC 3930  
 www.charltondegg.com.au

COUNCIL:  
CARDINIA SHIRE COUNCIL

TITLE:  
100 LECKY ROAD PTY LTD  
BANYAN PLACE FLP STAGE 5  
70-100 LECKY ROAD, OFFICER

LOCALITY PLAN, TYPICAL CROSS SECTIONS, SOT & SHEET INDEX

DRG NO. 1470_5_FLP/01	REV. D	SHEET 1 OF 4
--------------------------	-----------	--------------

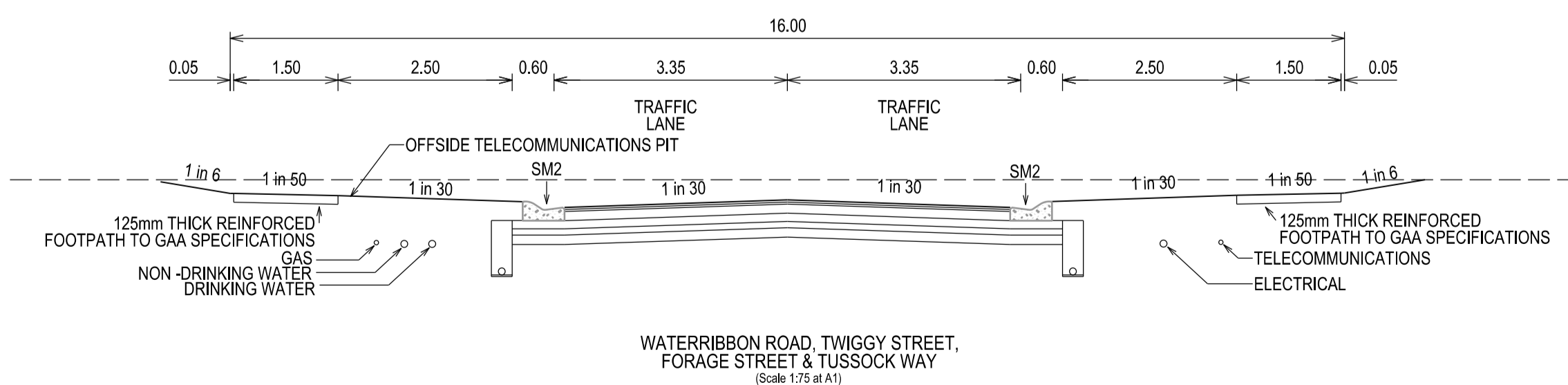

### SERVICE OFFSETS

Street	Gas	NDW	Water	Comms	Elec.	Lighting	Sewer
WATERRIBBON ROAD *	E 2.10	E 2.50	E 2.90	W 1.85	W 2.60	1.00 BOK	-
TWIGGY STREET *	N 1.90	N 2.30	N 2.70	S 1.85	S 2.60	1.00 BOK	S 1.00
FORAGE STREET *	N 2.10	N 2.50	N 2.90	S 1.85	S 2.60	1.00 BOK	N 1.00
TUSSOCK WAY *	N 2.10	N 2.50	N 2.90	S 1.85	S 2.60	1.00 BOK	S 1.00

SERVICE OFFSETS ARE MEASURED (m) FROM THE TITLE BOUNDARY UNLESS OTHERWISE SPECIFIED  
 \* OFFSETS BASED ON DN63 GAS, DN100 NDW & DN100 WATER. SERVICES IN EXCESS OF THIS SIZING WILL RESULT IN OFFSIDE OPTIC FIBRE PITS TO BE LOCATED IN FOOTPATH.  
 EXISTING SERVICES DENOTED WITH (E). EXISTING SERVICE OFFSETS ARE AN APPROXIMATE TO BE VERIFIED BY THE CONTRACTOR.

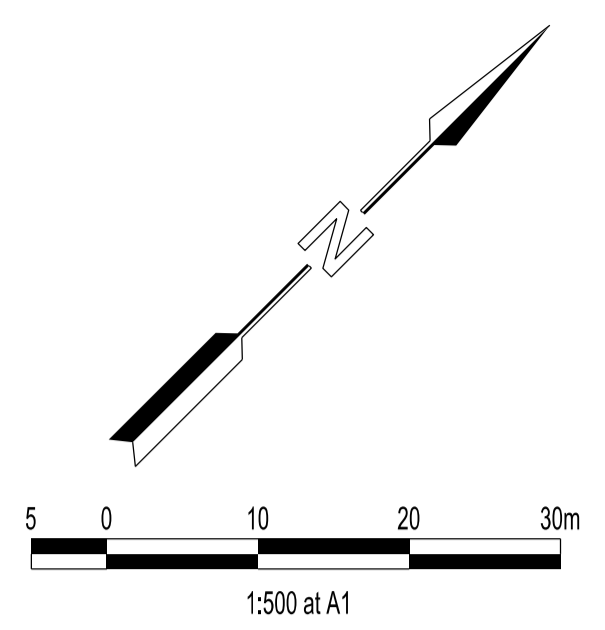

**FUNCTIONAL LAYOUT PLAN APPROVAL**  
**CARDINIA SHIRE COUNCIL**

Ref No.: S21-169  
 Sheet: 3 of 5  
 Approved by: Justin Conn  
**CARDINIA SHIRE COUNCIL**  
 Date: Tuesday, 28 February 2023

**LEGEND**

	FOOTPATH
	VEHICULAR CROSSOVER
	KERB AND CHANNEL
	ELECTRICITY } CONDUITS TELECOMMUNICATION } (REFER TO APPROVED ELECTRICAL AND COMMS PLAN)
	GAS } CONDUITS DRINKING WATER } NON DRINKING WATER }
	ELECTRICITY MAIN
	TELECOMMUNICATION MAIN
	GAS MAIN
	DRINKING WATER MAIN
	NON DRINKING WATER MAIN
	SEWER MAIN, MAINTENANCE STRUCTURES AND SEWER PROPERTY BRANCHES
	PROPOSED DRAINAGE, PIT, HOUSE DRAIN AND PROPERTY INLET
	EXISTING DRAINAGE AND PIT AND FUTURE DRAINAGE AND PIT
	MELBOURNE WATER SCHEME DRAINAGE AND PIT (COUNCIL ASSET)
	MELBOURNE WATER SCHEME DRAINAGE AND PIT (MELBOURNE WATER ASSET)
	DRAINAGE PIT NUMBER
	PROPOSED CUT AREAS
	PROPOSED FILL AREAS
	E00.00 EXISTING SURFACE LEVEL
	D00.00 DESIGN SURFACE LEVEL
	B00.00 TOP OF BATTER LEVEL
	P00.00 PADS LEVEL
	STREET NAME SIGN
	LOT SLOPE DIRECTION
	PERMANENT SURVEY MARK
	TEMPORARY BENCH MARK
	RETAINING WALLS
	KERB TRANSITION

**NOT FOR CONSTRUCTION**

**VERSION DETAILS:**

REV	DATE	DESCRIPTION	STATUS
A	04/06/2021	PRELIMINARY ISSUE	PRELIMINARY
B	21/06/2021	ADDITIONAL LOT ADDED. LOTS 520, 521, 522, 537 & 538 AMENDED.	PRELIMINARY
C	25/11/2021	KERB & ROAD X-SECT AMENDED, TURNING TEMPLATES ADDED. LOT 521 CROSSOVER SWAPPED.	PRELIMINARY
D	09/02/2023	CAR PARKING SPACES ADDED, DRAINAGE AMENDED & SPEED HUMP ADDED TO WATERIBBON RD	PRELIMINARY

FILENAME: P:\1470\1470\_5IE2 - Design\6 - DGN\FLP02\_SIS.dgn

DRAWN:	RC	DATE:	JUNE 2021	SCALE:	AS SHOWN
DESIGNED:	RC	DATE:	JUNE 2021	DATE PRINTED:	9/02/2023
AUTHORISED:	RB	DATE:	JUNE 2021		



COUNCIL: CARDINIA SHIRE COUNCIL

TITLE: 100 LECKY ROAD PTY LTD  
 BANYAN PLACE FLP STAGE 5  
 70-100 LECKY ROAD, OFFICER

FUNCTIONAL LAYOUT PLAN 1

DRG NO.	1470_5_FLP/02	REV.	D	SHEET 2 OF 4
---------	---------------	------	---	--------------

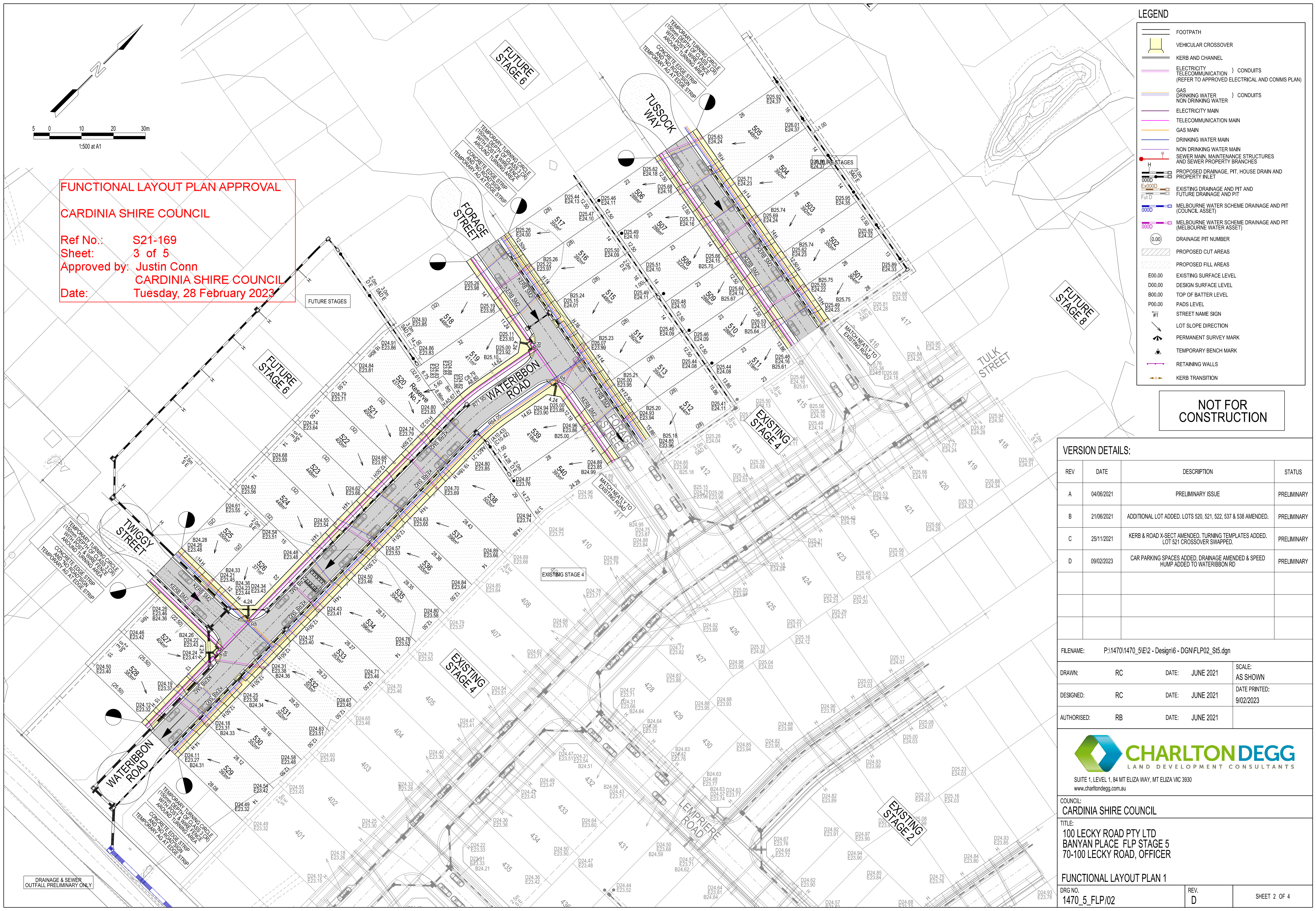

DRAINAGE & SEWER  
 OUTFALL PRELIMINARY ONLY

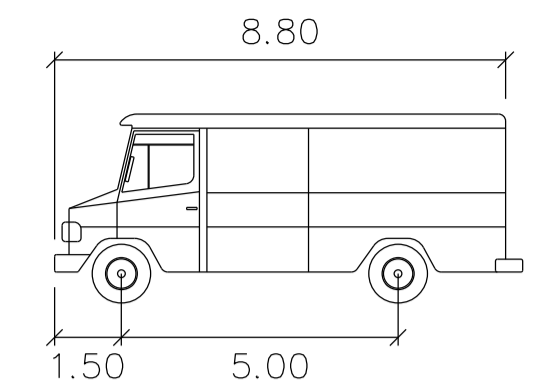
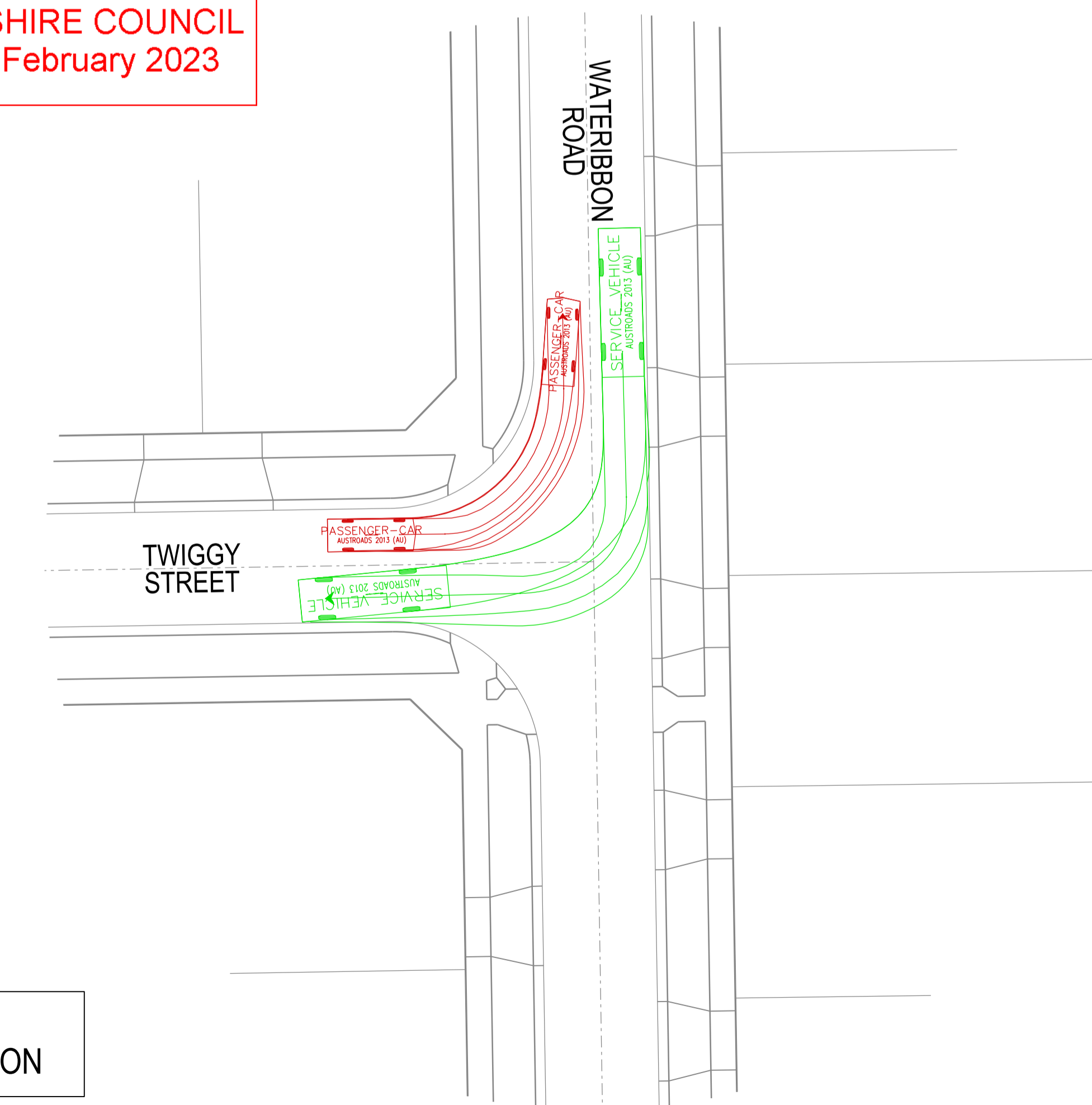
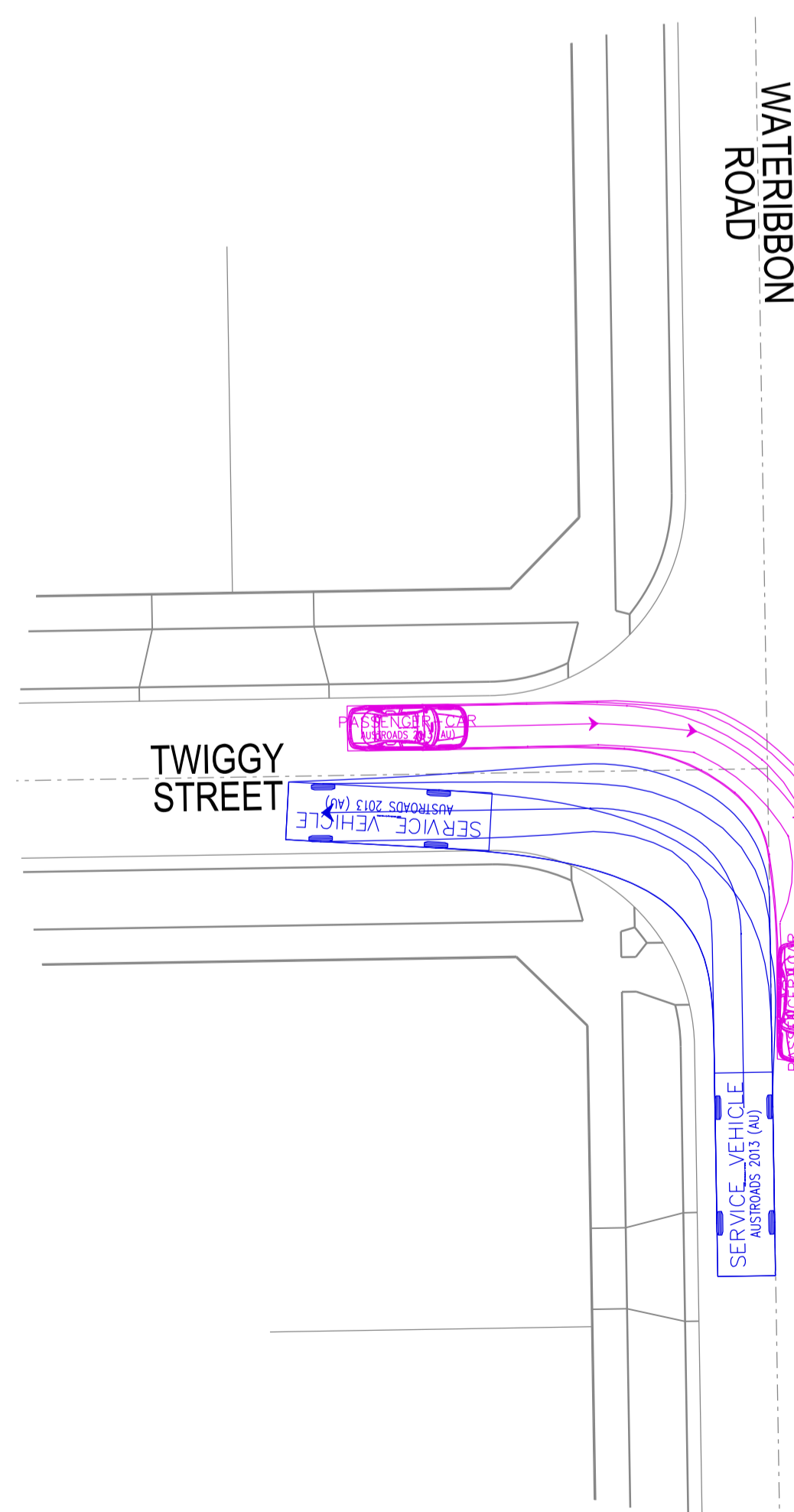
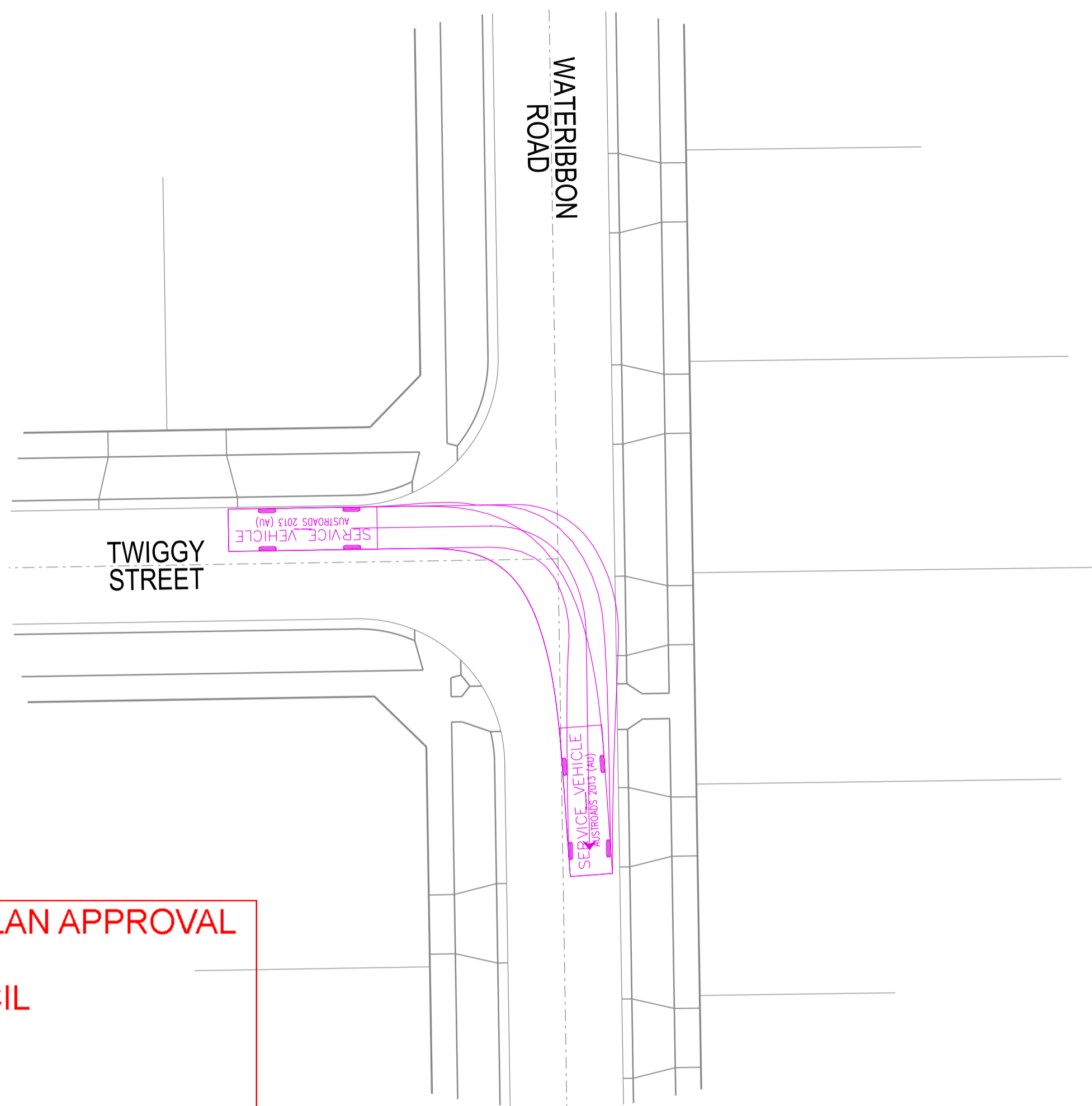
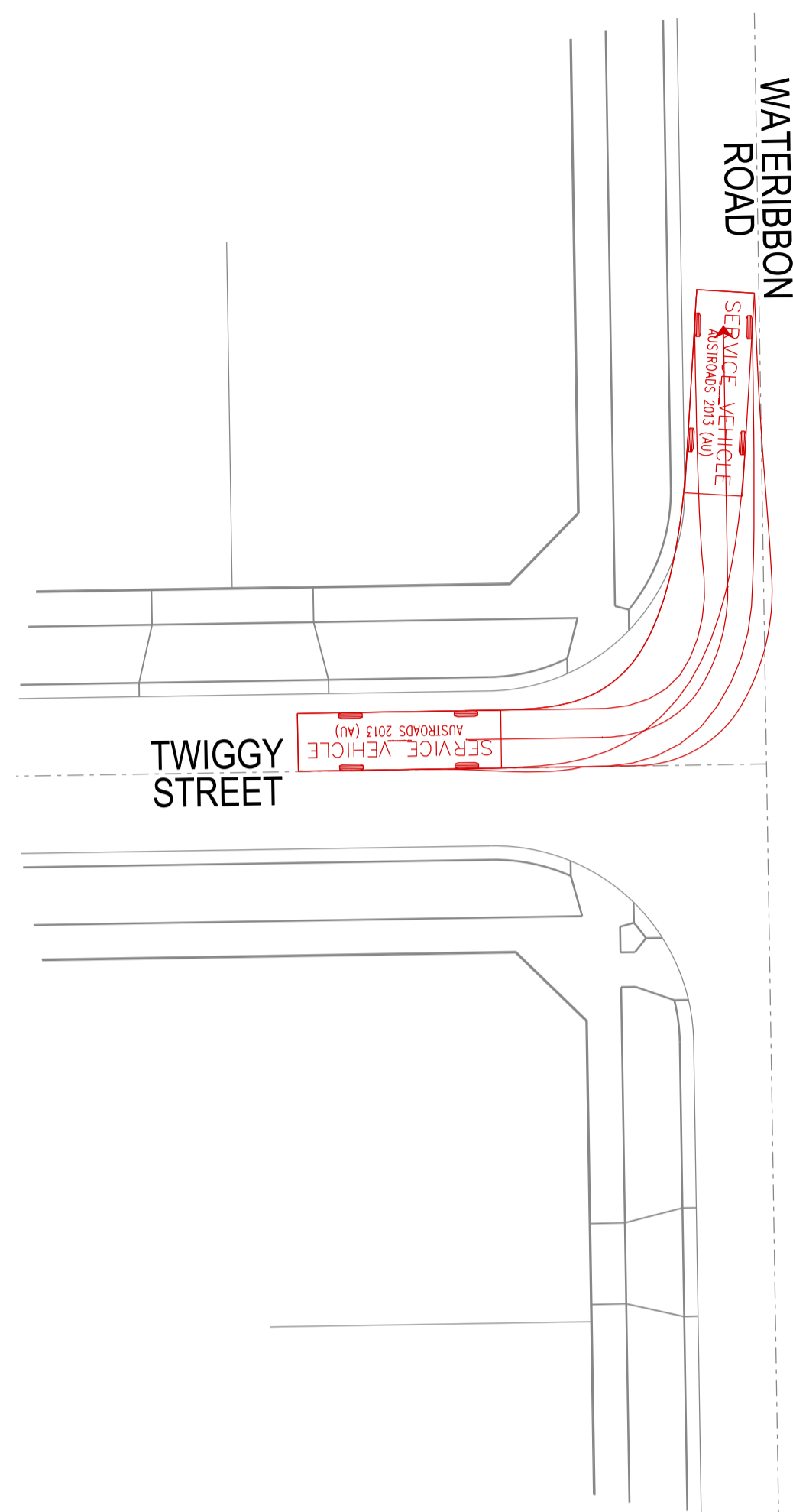

SERVICE VEHICLE

Width : 8.80 meters  
 Track : 5.00 meters  
 Lock to Lock Time : 6.0  
 Steering Angle : 38.7

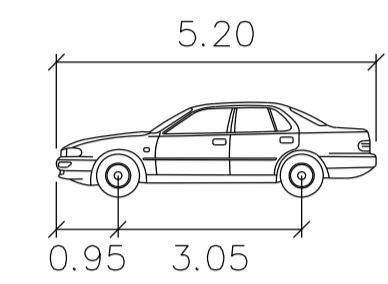

PASSENGER - CAR

Width : 5.20 meters  
 Track : 3.05 meters  
 Lock to Lock Time : 6.0  
 Steering Angle : 33.6

**FUNCTIONAL LAYOUT PLAN APPROVAL**

CARDINIA SHIRE COUNCIL

Ref No.: S21-169  
 Sheet: 4 of 5  
 Approved by: Justin Conn  
 CARDINIA SHIRE COUNCIL  
 Date: Tuesday, 28 February 2023

NOT FOR CONSTRUCTION

VERSION DETAILS:

REV	DATE	DESCRIPTION	STATUS
A	04/06/2021	PRELIMINARY ISSUE	PRELIMINARY
B	21/06/2021	ADDITIONAL LOT ADDED. LOTS 520, 521, 522, 537 & 538 AMENDED.	PRELIMINARY
C	25/11/2021	KERB & ROAD X-SECT AMENDED, TURNING TEMPLATES ADDED. LOT 521 CROSSOVER SWAPPED.	PRELIMINARY
D	09/02/2023	CAR PARKING SPACES ADDED, DRAINAGE AMENDED & SPEED HUMP ADDED TO WATERIBBON RD	PRELIMINARY

FILENAME: P:\1470\1470\_5IE\2 - Design\6 - DGN\FLP03\_S15.dgn

DRAWN:	RC	DATE:	JUNE 2021	SCALE:	AS SHOWN
DESIGNED:	RC	DATE:	JUNE 2021	DATE PRINTED:	9/02/2023
AUTHORISED:	RB	DATE:	JUNE 2021		



COUNCIL: CARDINIA SHIRE COUNCIL

TITLE: 100 LECKY ROAD PTY LTD  
 BANYAN PLACE FLP STAGE 5  
 70-100 LECKY ROAD, OFFICER

TURNING TEMPLATES

DRG NO. 1470_5_FLP/03	REV. D	SHEET 3 OF 4
--------------------------	-----------	--------------

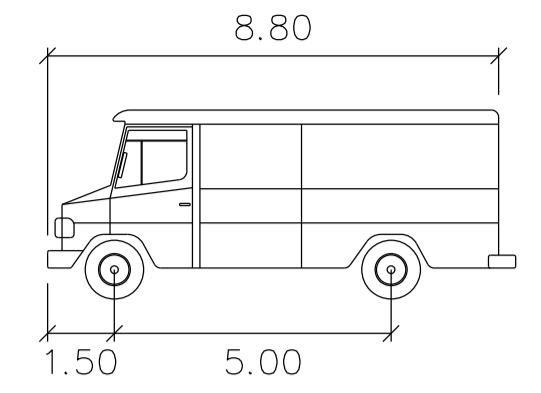

SERVICE VEHICLE

Width : 2.50 meters  
 Track : 2.50  
 Lock to Lock Time : 6.0  
 Steering Angle : 38.7

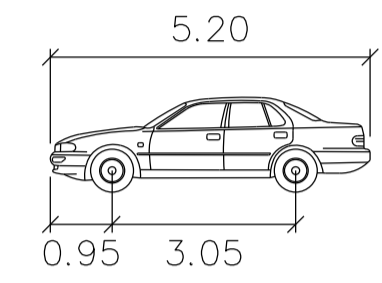

PASSENGER-CAR

Width : 1.94 meters  
 Track : 1.84  
 Lock to Lock Time : 6.0  
 Steering Angle : 33.6

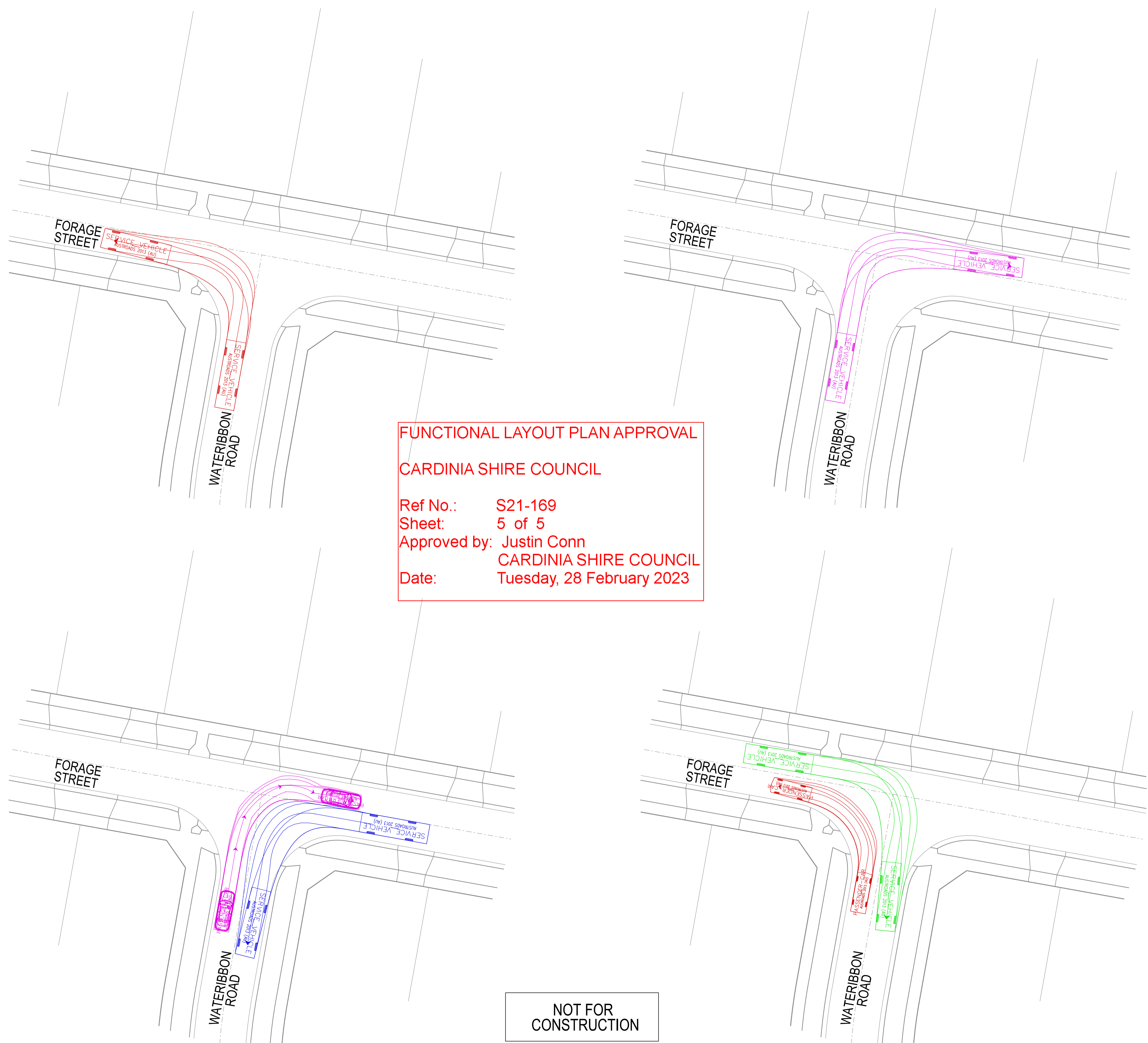

**FUNCTIONAL LAYOUT PLAN APPROVAL**  
**CARDINIA SHIRE COUNCIL**  
 Ref No.: S21-169  
 Sheet: 5 of 5  
 Approved by: Justin Conn  
**CARDINIA SHIRE COUNCIL**  
 Date: Tuesday, 28 February 2023

**NOT FOR CONSTRUCTION**

**VERSION DETAILS:**

REV	DATE	DESCRIPTION	STATUS
A	04/06/2021	PRELIMINARY ISSUE	PRELIMINARY
B	21/06/2021	ADDITIONAL LOT ADDED. LOTS 520, 521, 522, 537 & 538 AMENDED.	PRELIMINARY
C	25/11/2021	KERB & ROAD X-SECT AMENDED, TURNING TEMPLATES ADDED. LOT 521 CROSSOVER SWAPPED.	PRELIMINARY
D	09/02/2023	CAR PARKING SPACES ADDED, DRAINAGE AMENDED & SPEED HUMP ADDED TO WATERRIBBON RD	PRELIMINARY

FILENAME: P:\1470\1470\_5\E\2 - Design\6 - DGN\FLP04\_S15.dgn

DRAWN:	RC	DATE:	JUNE 2021	SCALE:	AS SHOWN
DESIGNED:	RC	DATE:	JUNE 2021	DATE PRINTED:	9/02/2023
AUTHORISED:	RB	DATE:	JUNE 2021		



COUNCIL: CARDINIA SHIRE COUNCIL  
 TITLE: 100 LECKY ROAD PTY LTD  
 BANYAN PLACE FLP STAGE 5  
 70-100 LECKY ROAD, OFFICER

DRG NO. 1470_5_FLP/04	REV. D	SHEET 3 OF 4
--------------------------	-----------	--------------